

Product Type: IP67 connector

Product Name:ESF-RS100A16BL

Product Description: Connectors suitable for energy storage modules: Color: Black Wire cross-section: 16mm<sup>2</sup> Rated voltage: 1500V DC Rated current: 100A Connection method: screw Contact type: Pin

Product Size

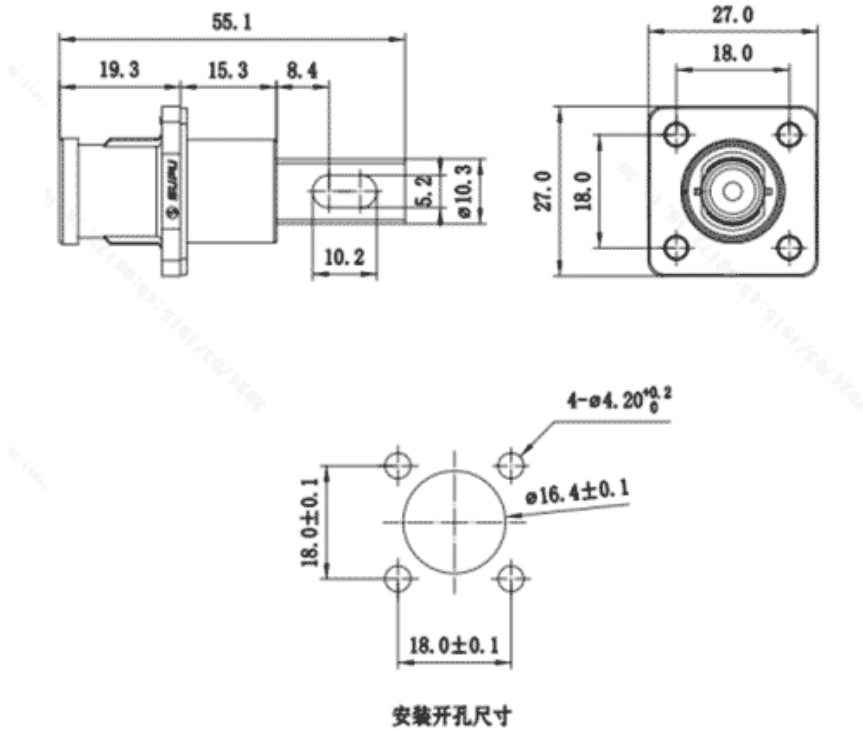

Parameters

☞ SUPU ID	ESF-RS100A16BL
☞ Number of connections	1
☞ Connection method	Screw thread

☞ Protection Level	IP67
☞ Operating temperature range	-40°C~125°C
☞ Insulation material	PA
☞ Insulation material group	III
☞ Contact material	Copper alloy
☞ Contact plating	Ag,Plated
☞ Insertion/withdrawal cycles	100
☞ Insertion force	≤75N
☞ Withdrawal force	≥10N

## Technical data

☞ IEC Rated Current	100A
☞ IEC Rated Voltage	1500V
☞ Overvoltage category	III
☞ Degree of pollution	3
☞ Rated impulse voltage	12.3KV
☞ Stripping length	/
☞ Rated cross section(AWG)	16mm <sup>2</sup> (AWG6)
☞ External cable diameter	/

## Commercial data

☞ Order No	ESF-RS100A16BL
☞ Packing unit	1
☞ Minimum order quantity	PCS

Weight per unit (without packaging)

0.74KG

Single piece weight

0.7KG

## Ningbo SUPU Electronics Co., Ltd.

Address: No. 150, Xinxing 4th Road, High-tech Industrial Development Zone,  
Cixi City, Zhejiang Province, China

Zip code: 315303

Switchboard: +86 574-63288158

Fax: +86 574-63288170

E-mail:supucontact@supu.cn

Service Hotline: 400-626-6336



Wechat