



Product Type: IP67 connector

Product Name:ESF-
PS100A16BN

Product Description: Connectors suitable for energy storage modules Color: Black Rated voltage: 1500V DC Rated current: 100A Connection method: crimping Contact type: Socket wire cross-section: 16mm² cable outer diameter: 7.1mm to 7.8mm

Product Size

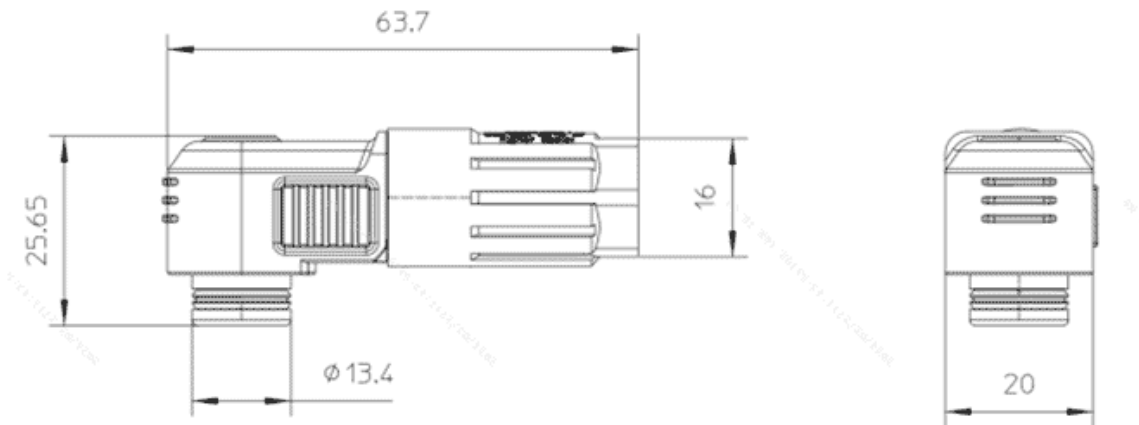

Parameters

☞ SUPU ID

ESF-PS100A16BN

☞ Number of connections

1

☞ Connection method	Crimp
☞ Protection Level	IP67
☞ Operating temperature range	-40°C~125°C
☞ Insulation material	PA
☞ Insulation material group	III
☞ Contact material	Copper alloy
☞ Contact plating	Ag,Plated
☞ Insertion/withdrawal cycles	100
☞ Insertion force	≤75N
☞ Withdrawal force	≥10N

Technical data

☞ IEC Rated Current	100A
☞ IEC Rated Voltage	1500V
☞ Overvoltage category	III
☞ Degree of pollution	3
☞ Rated impulse voltage	12.3KV
☞ Stripping length	20mm±1mm
☞ Rated cross section(AWG)	16mm ² (AWG6)
☞ External cable diameter	7.1mm~7.8mm

Commercial data

☞ Order No	ESF-PS100A16BN
☞ Packing unit	1

☞ Minimum order quantity	PCS
☞ Weight per unit (without packaging)	0.98KG
☞ Single piece weight	0.94KG

Ningbo SUPU Electronics Co., Ltd.

Address: No. 150, Xinxing 4th Road, High-tech Industrial Development Zone,
Cixi City, Zhejiang Province, China

Zip code: 315303

Switchboard: +86 574-63288158

Fax: +86 574-63288170

E-mail:supucontact@supu.cn

Service Hotline: 400-626-6336



Wechat